

8 7 6 5 4 3 2 1

P/N	COLOR
21705	BLACK

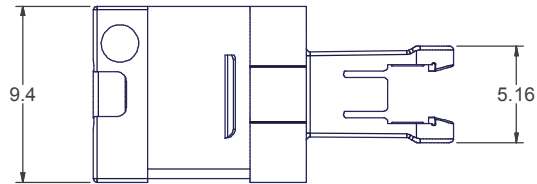
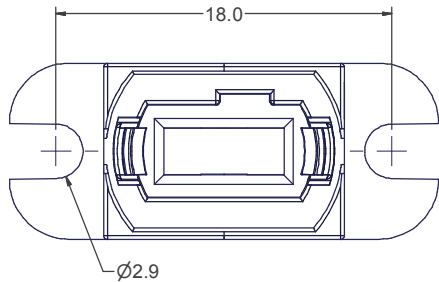
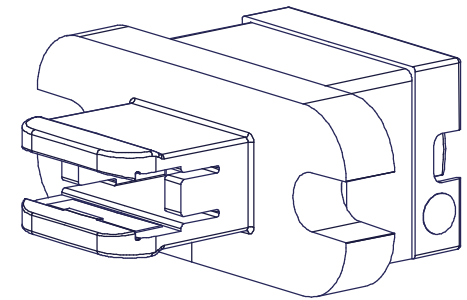
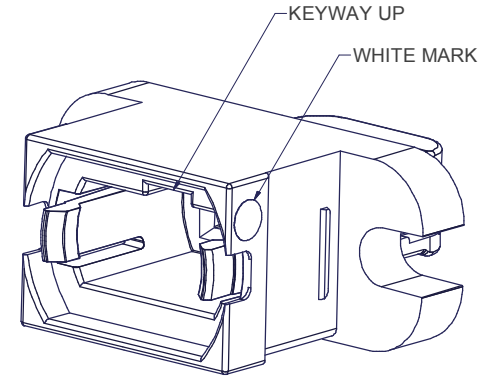
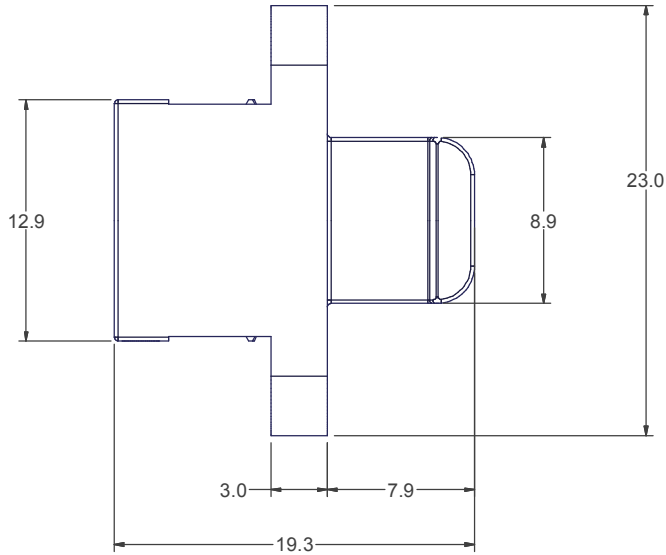

▲ DENOTES CRITICAL DIMENSION

NOTES:

- 1. OPTIMIZED FOR USE WITH USCONEC MT FERRULES.

USCONEC LTD. PROPRIETARY THIS DOCUMENT AND THE ASSOCIATED DATA CONTAIN RESTRICTED INFORMATION THAT IS USCONEC LTD. PROPERTY. DISCLOSE OR DUPLICATE FOR OTHERS ONLY AS AUTHORIZED BY USCONEC LTD.			
Material:		PEI - MAT'L SPEC #C10975	
REV	DATE	DESCRIPTION	ECN
X1	9/17/19	-	2217-my
A	11/14/19	INITIAL RELEASE	2245-mm

CUSTOMER DRAWING

DIMENSIONS FOR REFERENCE ONLY

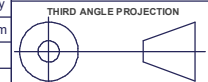

METRIC/mm

USCONEC Hickory, NC
800-769-0944
www.usconec.com

TITLE
ADAPTER, MT TO MTP-16™, SC FOOTPRINT, FULL FLANGE

SIZE	S&M Part No.:	DWG NO.	REV
B	SEE TABLE	C21705	A
SCALE	Drafter	Date:	SHEET
N.T.S.	M. YOUNT	8/27/2019	1 OF 1

8 7 6 5 4 3 2 1