

P/N	COLOR
21436	BLACK
23133	GREEN
23134	BEIGE
25225	WHITE

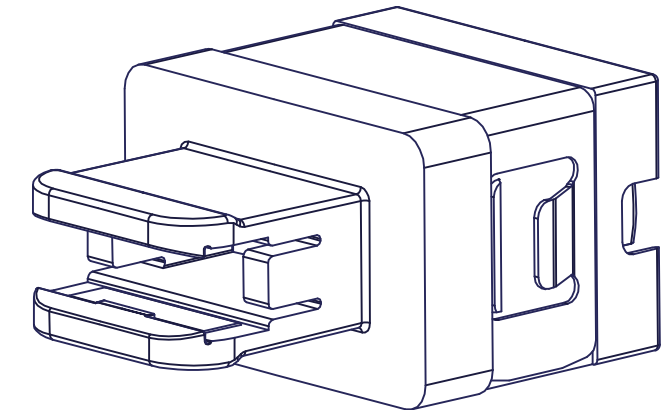
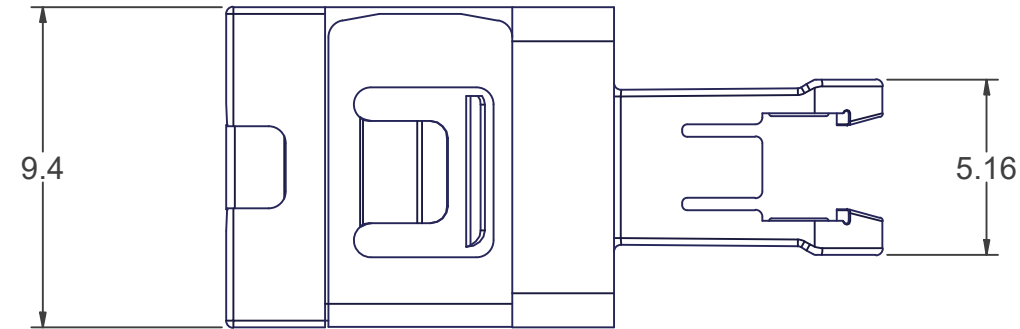
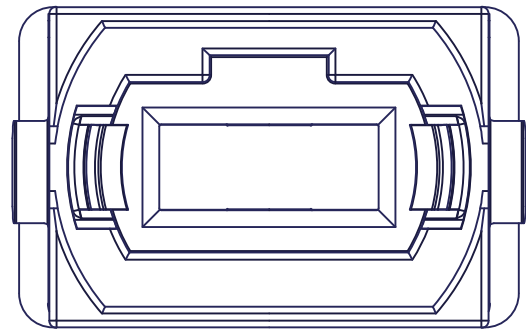
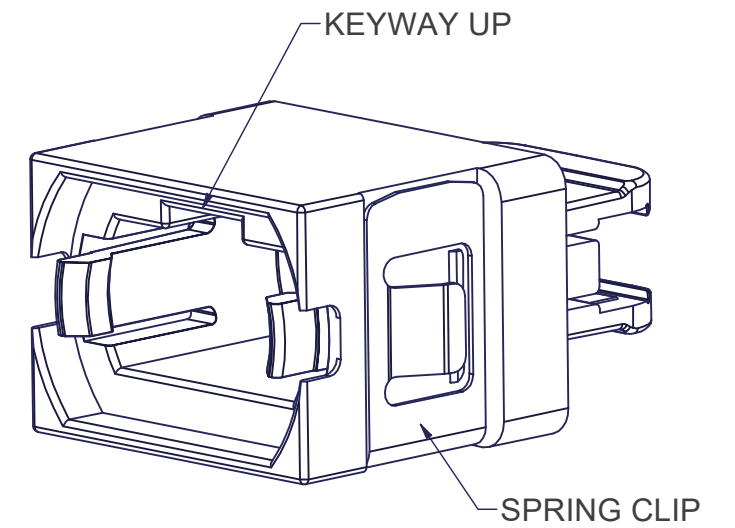
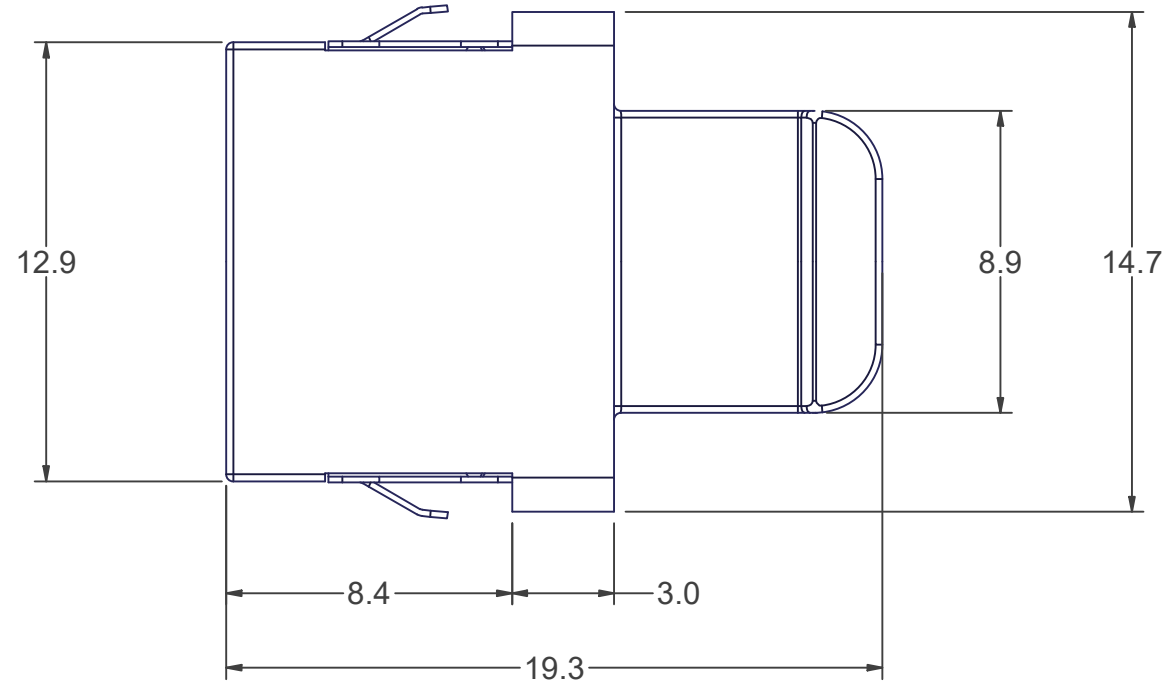

NOTES:

- ADAPTER BODY COLOR: SEE TABLE
- OPTIMIZED FOR USE WITH USCONEC MT FERRULES.

PART	MATERIAL
ADAPTER BODY	POLYETHERIMIDE
SPRING CLIP	STAINLESS STEEL

USCONEC LTD. PROPRIETARY			
THIS DOCUMENT AND THE ASSOCIATED DATA CONTAIN RESTRICTED INFORMATION THAT IS USCONEC LTD. PROPERTY. DISCLOSE OR DUPLICATE FOR OTHERS ONLY AS AUTHORIZED BY USCONEC LTD.			
Material:		SEE TABLE AT LEFT	
REV.	DATE	DESCRIPTION	ECN
X1	4/23/19	---	mm
A	9/20/19	INITIAL RELEASE	2217-my
B	11/15/19	REVISED VIEWS; REVISED NOTE 2	2217-my
C	5/12/21	ADDED P/N's 23133 (GREEN) & 23134 (BEIGE) TO TABLE	2217-mm
D	10/31/24	ADDED P/N 25225 (WHITE) TO TABLE; REMOVED WHITE MARK ON ALL PARTS	2661-mm

CUSTOMER DRAWING

DIMENSIONS FOR REFERENCE ONLY

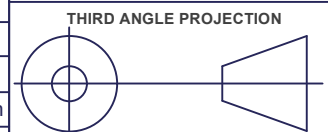

METRIC/mm

USCONEC Hickory, NC
800-769-0944
www.usconec.com

TITLE
ADAPTER W/ CLIP, MT TO MTP®, SC FOOTPRINT

SIZE **B** S&M Part No.: SEE TABLE DWG NO. **C21436** REV **D**
SCALE N.T.S. Drafter M.McCROSKEY Date: 4/23/2019 SHEET 1 OF 1

▲ DENOTES CRITICAL DIMENSION