

Parts List			
ITEM	DESCRIPTION	PART NUMBER	NOTES
1	BOOT, ROUND, MTP®	8041	
2	CRIMP RING	16425	
3	SPRING PUSH, UNIV., 3.0mm RND	19692	
4	SPRING, UNIVERSAL, 9.8N, MTP®	17167	
5	PIN CLAMP or PIN SPACER	SEE KIT TABLE COLUMN A	NOTE 1
6	ASSEMBLY, HOUSING, MTP®	SEE KIT TABLE COLUMN B	
7	DUST CAP, MTP®	17242	

**NOTES:**

1. MALE CONNECTOR KIT HAS PIN CLAMP ASSEMBLY. FEMALE CONNECTOR KIT HAS FEMALE PIN SPACER.
2. HEAT-SHRINK TUBING RECOMMENDED FOR SECURING CRIMP BAND TO CABLE. HEAT-SHRINK TUBING NOT INCLUDED.

KIT P/N	KIT DESCRIPTION	PERFORMANCE	COLUMN A	COLUMN B	HSG ASSY COLOR
			PIN CLAMP/SPACER P/N	HSG ASSY P/N	
20136	KIT, MTP®, UNIV., FEMALE, MM, 2.5mm RND, BEIGE	MM	17795	MTP-A12-11	BEIGE
20137	KIT, MTP®, UNIV., MALE, MM, 2.5mm RND, BEIGE	MM	17799	MTP-A12-11	BEIGE
20138	KIT, MTP®, UNIV., FEMALE, MM, 2.5mm RND, BLACK	MM	17795	MTP-A12-02	BLACK
20139	KIT, MTP®, UNIV., MALE, MM, 2.5mm RND, BLACK	MM	17799	MTP-A12-02	BLACK
20140	KIT, MTP®, UNIV., FEMALE, MM, 2.5mm RND, AQUA	MM or MM MTP Elite®	17795	7871	AQUA
20141	KIT, MTP®, UNIV., MALE, MM, 2.5mm RND, AQUA	MM	17799	7871	AQUA
20142	KIT, MTP®, UNIV., MALE, MM MTP Elite®, 2.5mm RND, AQUA	MM MTP Elite®	17800	7871	AQUA
20143	KIT, MTP®, UNIV., FEMALE, MM, 2.5mm RND, MAGENTA	MM or MM MTP Elite®	17795	13949	MAGENTA
20144	KIT, MTP®, UNIV., MALE, MM, 2.5mm RND, MAGENTA	MM	17799	13949	MAGENTA
20145	KIT, MTP®, UNIV., MALE, MM MTP Elite®, 2.5mm RND, MAGENTA	MM MTP Elite®	17800	13949	MAGENTA
20146	KIT, MTP®, UNIV., FEMALE, MM, 2.5mm RND, HEATHER VIOLET	MM or MM MTP Elite®	17795	16693	HEATHER VIOLET
20147	KIT, MTP®, UNIV., MALE, MM, 2.5mm RND, HEATHER VIOLET	MM	17799	16693	HEATHER VIOLET
20148	KIT, MTP®, UNIV., MALE, MM MTP Elite®, 2.5mm RND, HEATHER VIOLET	MM MTP Elite®	17800	16693	HEATHER VIOLET
20149	KIT, MTP®, UNIV., FEMALE, MM, 2.5mm RND, MUNSELL VIOLET	MM or MM MTP Elite®	17795	16791	MUNSELL VIOLET
20150	KIT, MTP®, UNIV., MALE, MM, 2.5mm RND, MUNSELL VIOLET	MM	17799	16791	MUNSELL VIOLET
20151	KIT, MTP®, UNIV., MALE, MM MTP Elite®, 2.5mm RND, MUNSELL VIOLET	MM MTP Elite®	17800	16791	MUNSELL VIOLET
20152	KIT, MTP®, UNIV., FEMALE, MM, 2.5mm RND, LIME	MM or MM MTP Elite®	17795	18829	LIME
20153	KIT, MTP®, UNIV., MALE, MM, 2.5mm RND, LIME	MM	17799	18829	LIME
20154	KIT, MTP®, UNIV., MALE, MM MTP Elite®, 2.5mm RND, LIME	MM MTP Elite®	17800	18829	LIME
20155	KIT, MTP®, UNIV., FEMALE, SM, 2.5mm RND, GREEN	SM	17795	16007	GREEN
20156	KIT, MTP®, UNIV., MALE, SM, 2.5mm RND, GREEN	SM	17800	16007	GREEN
20157	KIT, MTP®, UNIV., FEMALE, SM MTP Elite®, 2.5mm RND, YELLOW	SM MTP Elite®	17795	16918	YELLOW
20158	KIT, MTP®, UNIV., MALE, SM MTP Elite®, 2.5mm RND, YELLOW	SM MTP Elite®	17801	16918	YELLOW

FERRULE / BOOT KIT SHOWN FOR REFERENCE ONLY, MUST BE PURCHASED SEPARATELY

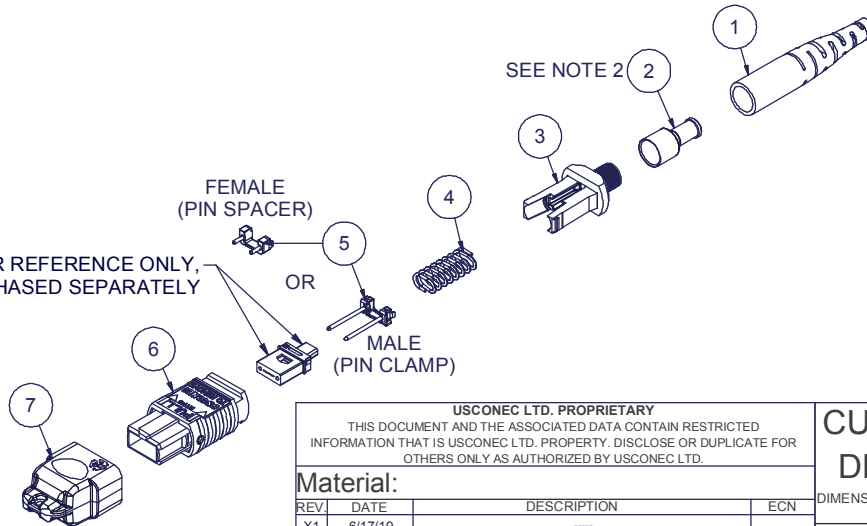

USCONEC LTD. PROPRIETARY  
THIS DOCUMENT AND THE ASSOCIATED DATA CONTAIN RESTRICTED INFORMATION THAT IS USCONEC LTD. PROPERTY. DISCLOSE OR DUPLICATE FOR OTHERS ONLY AS AUTHORIZED BY USCONEC LTD.

**Material:**

REV.	DATE	DESCRIPTION	ECN
X1	6/17/19	----	2183-mm
A	7/2/19	INITIAL RELEASE	

**CUSTOMER DRAWING**

DIMENSIONS FOR REFERENCE ONLY

THIRD ANGLE PROJECTION

**METRIC/mm**

▲ DENOTES CRITICAL DIMENSION

Hickory, NC  
800-769-0944  
[www.usconec.com](http://www.usconec.com)

**USCONEC**

TITLE  
KIT, MTP® CONNECTOR, UNIVERSAL,  
2.3 - 2.7 mm ROUND CABLE

SIZE <b>A3</b>	S&M Part No.: SEE TABLE	DWG NO. <b>C20136</b>	REV A
SCALE N.T.S.	Drafter M. McCROSKEY	Date 6/17/2019	SHEET 1 OF 2

6 5 4 3 2 1

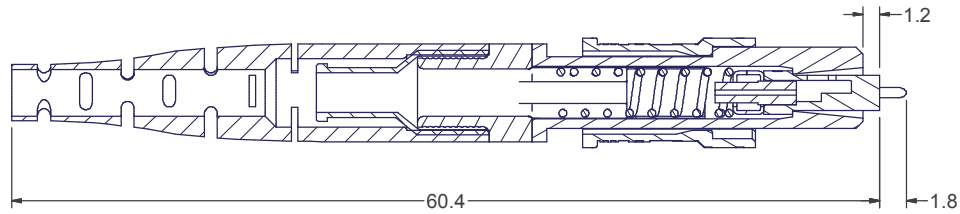
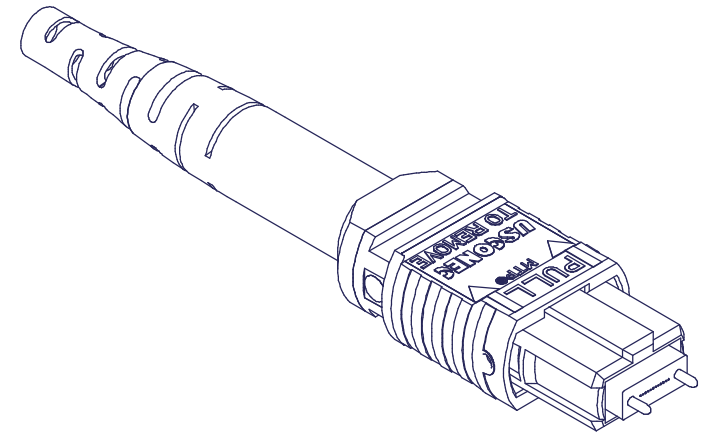
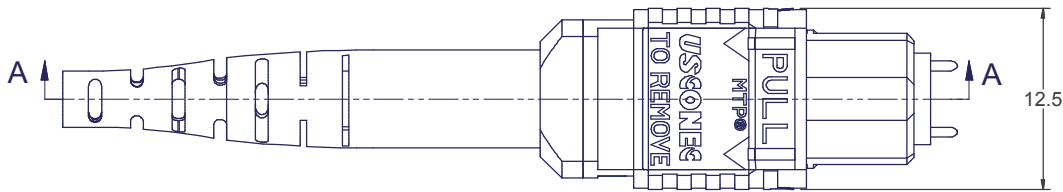
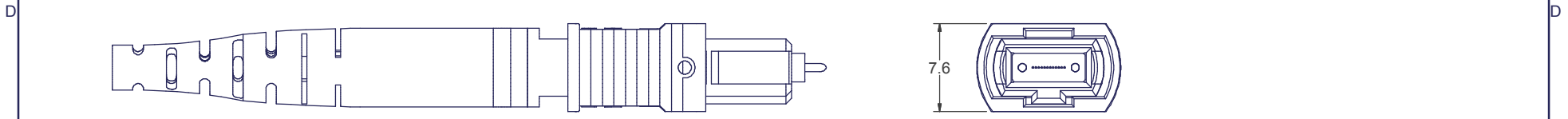

SECTION A-A

▲ DENOTES CRITICAL DIMENSION

USCONEC LTD. PROPRIETARY  
THIS DOCUMENT AND THE ASSOCIATED DATA CONTAIN RESTRICTED INFORMATION THAT IS USCONEC LTD. PROPERTY. DISCLOSE OR DUPLICATE FOR OTHERS ONLY AS AUTHORIZED BY USCONEC LTD.

Material:

REV.	DATE	DESCRIPTION	ECN

CUSTOMER DRAWING

DIMENSIONS FOR REFERENCE ONLY

THIRD ANGLE PROJECTION



METRIC/mm



Hickory, NC  
800-769-0944  
[www.usconec.com](http://www.usconec.com)

TITLE  
KIT, MTP® CONNECTOR, UNIVERSAL,  
2.3 - 2.7 mm ROUND CABLE

SIZE <b>A3</b>	S&M Part No.: SEE TABLE	DWG NO. <b>C20136</b>	REV A
SCALE N.T.S.	Drafter M. McCROSKEY	Date 6/17/2019	SHEET 2 OF 2

6 5 4 3 2 1