

8 7 6 5 4 3 2 1

P/N	COLOR
19695	BLACK
23131	GREEN
23132	BEIGE
23353	GRAY

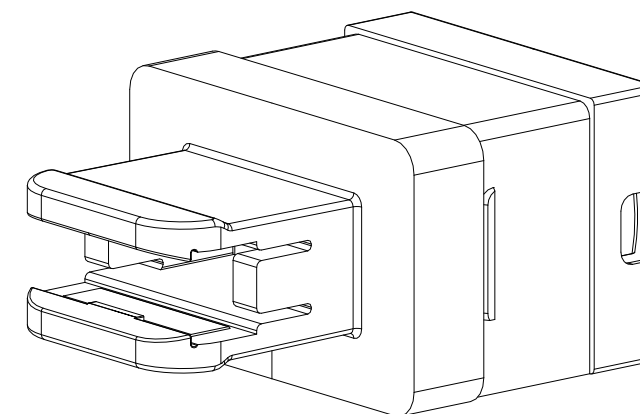
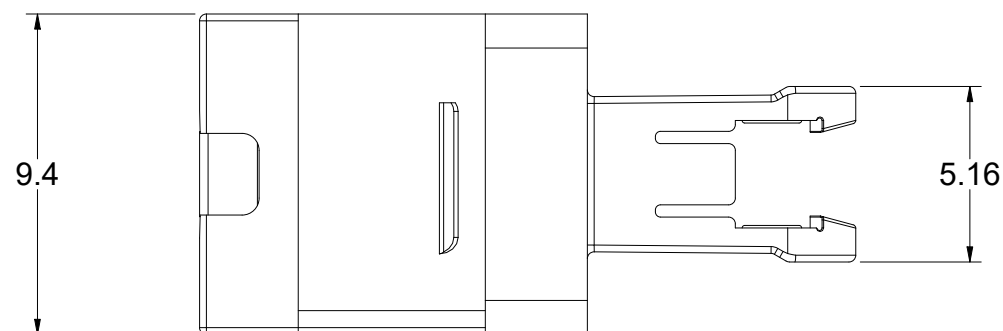
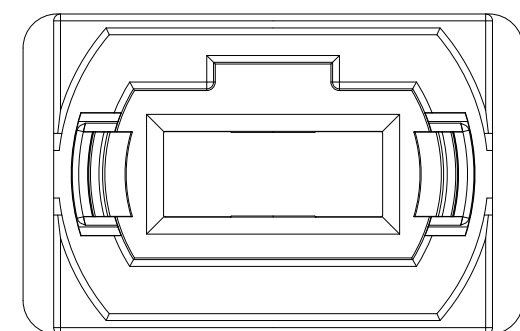
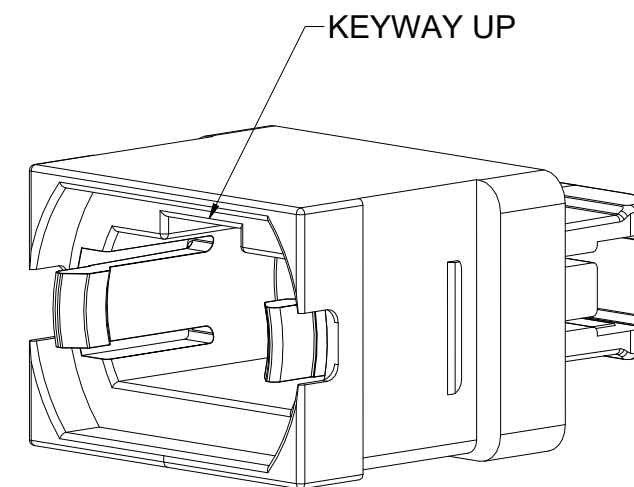
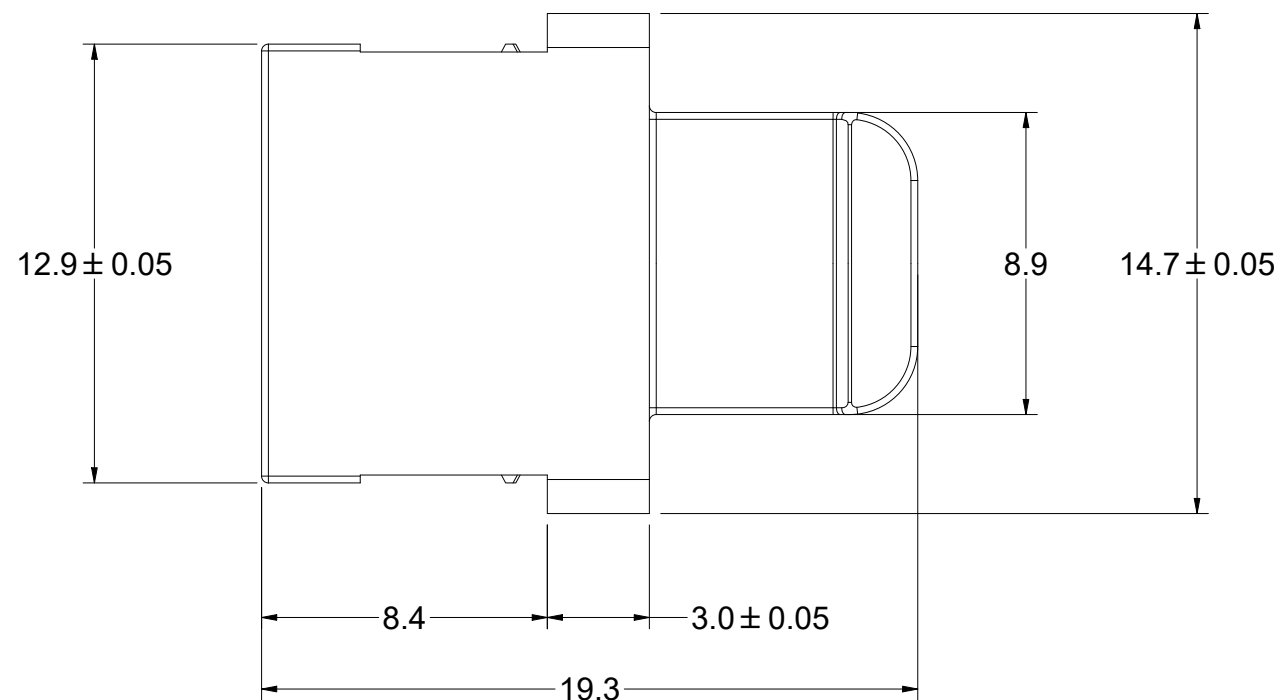

NOTES:

1. OPTIMIZED FOR USE WITH USCONEC MT FERRULES.

USCONEC LTD. PROPRIETARY
THIS DOCUMENT AND THE ASSOCIATED DATA CONTAIN RESTRICTED INFORMATION THAT IS USCONEC LTD. PROPERTY. DISCLOSE OR DUPLICATE FOR OTHERS ONLY AS AUTHORIZED BY USCONEC LTD.

Material: PEI / MAT'L SPEC #C10975

REV.	DATE	DESCRIPTION	ECN
A	9/20/19	INITIAL RELEASE	2217-my
B	11/15/19	ADDED NOTE 1	2217-my
C	5/12/21	ADDED P/N's 23131 (GREEN) & 23132 (BEIGE) TO TABLE	2217-mm
D	9/27/21	ADDED P/N's 23353 (GRAY) TO TABLE	
E	10/8/24	REMOVED WHITE MARK	2708-mm

CUSTOMER DRAWING

DIMENSIONS FOR REFERENCE ONLY

THIRD ANGLE PROJECTION

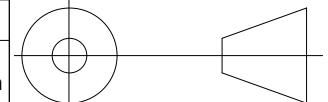

METRIC/mm

▲ DENOTES CRITICAL DIMENSION



Hickory, NC
800-769-0944
www.usconec.com

TITLE
ADAPTER, MT TO MTP®,
SC FOOTPRINT

SIZE B	S&M Part No.: SEE TABLE	DWG NO. C19695	REV E
SCALE N.T.S.	Drafter M. YOUNT	Date: 8/30/2018	SHEET 1 OF 1

8 7 6 5 4 3 2 1