

Parts List				
ITEM	DESCRIPTION	PART NUMBER	QTY	NOTES
1	BOOT, ROUND	13168	1	
2	CRIMP BAND	16543	1	
3	SPRING PUSH, UNIV., 2 PC, 4.0 - 5.5mm RND, MTP®	22900	1	
4	SPRING, UNIVERSAL, 20N	22515	1	
5	PIN CLAMP	SEE KIT TABLE COLUMN A	1	NOTE 1
6	HOUSING ASSY, MTP® PRO	SEE KIT TABLE COLUMN B	1	
7	DUST CAP	17242	1	

KIT P/N	KIT DESCRIPTION	PERFORMANCE	COLUMN A PIN CLAMP P/N	COLUMN B HSG ASSY P/N	HSG COLOR
18616	KIT, MTP® PRO, FEMALE, MM MTP Elite®, 4.0 RND, HSF, AQUA HSG	MM MTP Elite®	25084	18189	AQUA
18617	KIT, MTP® PRO, MALE, MM MTP Elite®, 4.0 RND, HSF, AQUA HSG	MM MTP Elite®	25085	18189	AQUA
18618	KIT, MTP® PRO, FEMALE, MM MTP Elite®, 4.0 RND, HSF, HEATHER VIOLET HSG	MM MTP Elite®	25084	18191	HEATHER VIOLET
18619	KIT, MTP® PRO, MALE, MM MTP Elite®, 4.0 RND, HSF, HEATHER VIOLET HSG	MM MTP Elite®	25085	18191	HEATHER VIOLET
18620	KIT, MTP® PRO, FEMALE, SM MTP Elite®, 4.0 RND, HSF, GREEN HSG	SM MTP Elite®	25084	18190	GREEN
18621	KIT, MTP® PRO, MALE, SM MTP Elite®, 4.0 RND, HSF, GREEN HSG	SM MTP Elite®	25087	18190	GREEN
20956	KIT, MTP® PRO, FEMALE, MM MTP Elite®, 4.0 RND, HSF, LIME HSG	MM MTP Elite®	25084	19486	LIME
20957	KIT, MTP® PRO, MALE, MM MTP Elite®, 4.0 RND, HSF, LIME HSG	MM MTP Elite®	25085	19486	LIME

NOTES:

1. MALE CONNECTOR KIT HAS MALE PIN CLAMP ASSEMBLY, FEMALE CONNECTOR KIT HAS FEMALE PIN CLAMP ASSEMBLY.

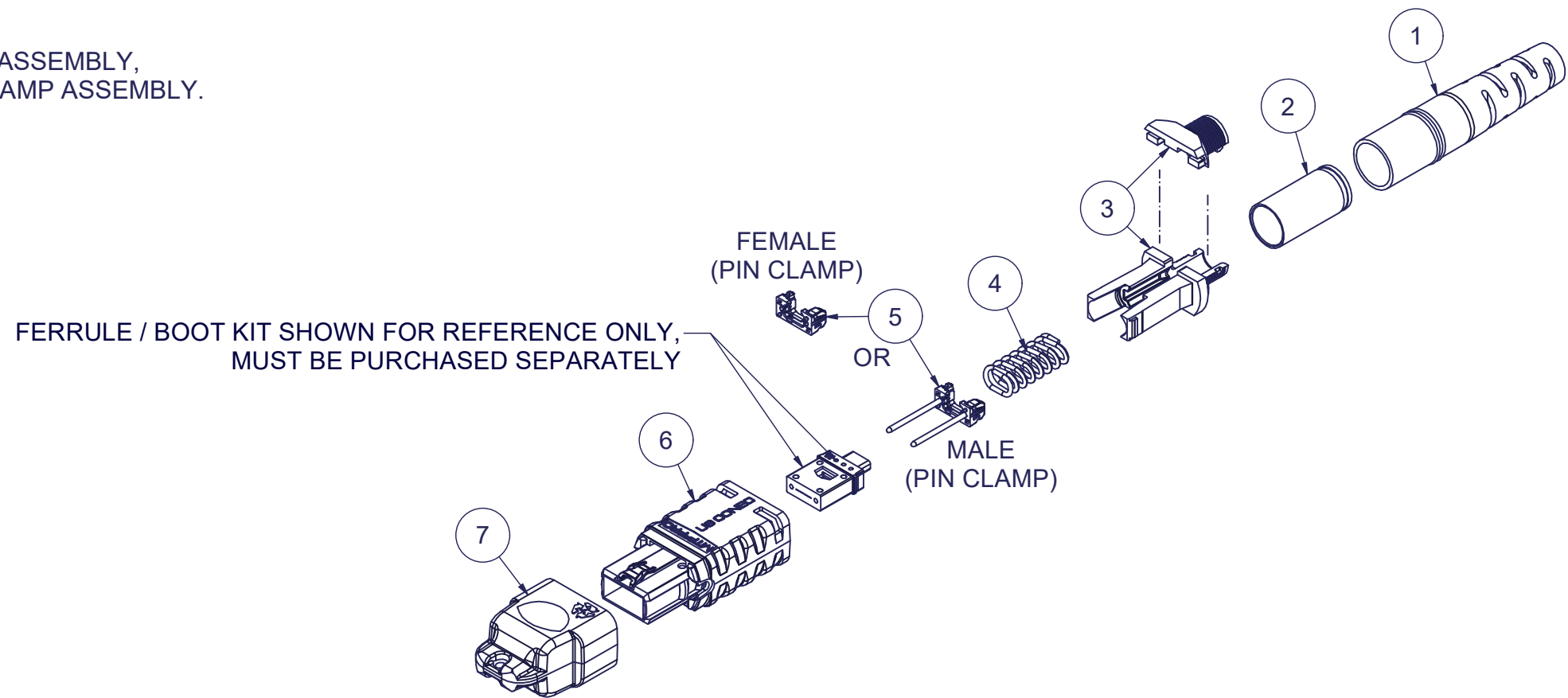

USCONEC LTD. PROPRIETARY
THIS DOCUMENT AND THE ASSOCIATED DATA CONTAIN RESTRICTED INFORMATION THAT IS USCONEC LTD. PROPERTY. DISCLOSE OR DUPLICATE FOR OTHERS ONLY AS AUTHORIZED BY USCONEC LTD.

Material:

REV.	DATE	DESCRIPTION	ECN
X1	5/9/18	-	2079-mm
A	1/20/20	INITIAL RELEASE	2079-my
B	1/31/20	ADDED LIME P/N'S 20956 & 20957	2079-mm
C	7/28/22	SPRING PUSH 22900 was 19740	2485-mm
D	4/11/25	PIN CLAMP CHGS: 25084 was 17861; 25085 was 19038; 25087 was 19039; SPRING CHG: 22515 was 17698	2754-mm

CUSTOMER DRAWING

DIMENSIONS FOR REFERENCE ONLY

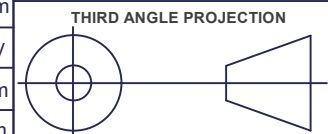

METRIC/mm

▲ DENOTES CRITICAL DIMENSION

USCONEC Hickory, NC
800-769-0944
www.usconec.com

TITLE
KIT, MTP® PRO CONN., 3.8 - 4.2 mm RND CBL, HIGH SPRING FORCE

SIZE A3	S&M Part No.: SEE TABLE	DWG NO. C18616	REV D
SCALE N.T.S.	Drafter M.McCROSKEY	Date: 5/9/2018	SHEET 1 OF 2

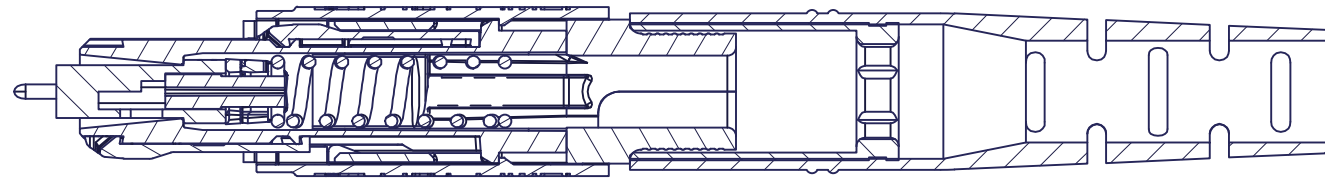
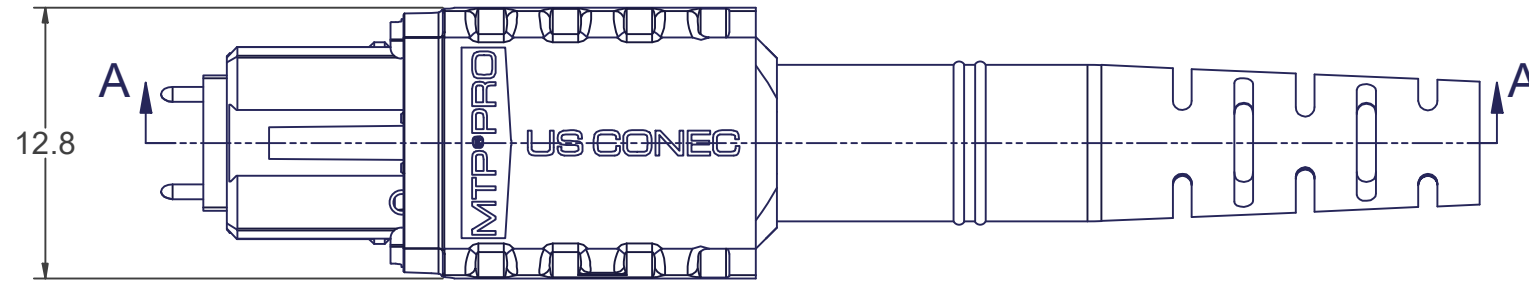
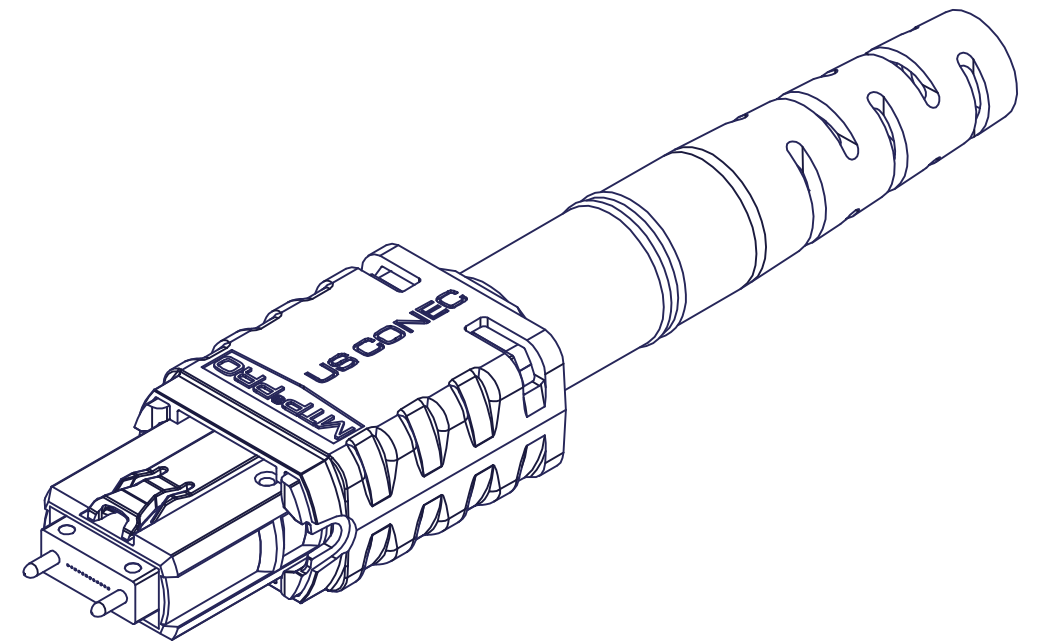
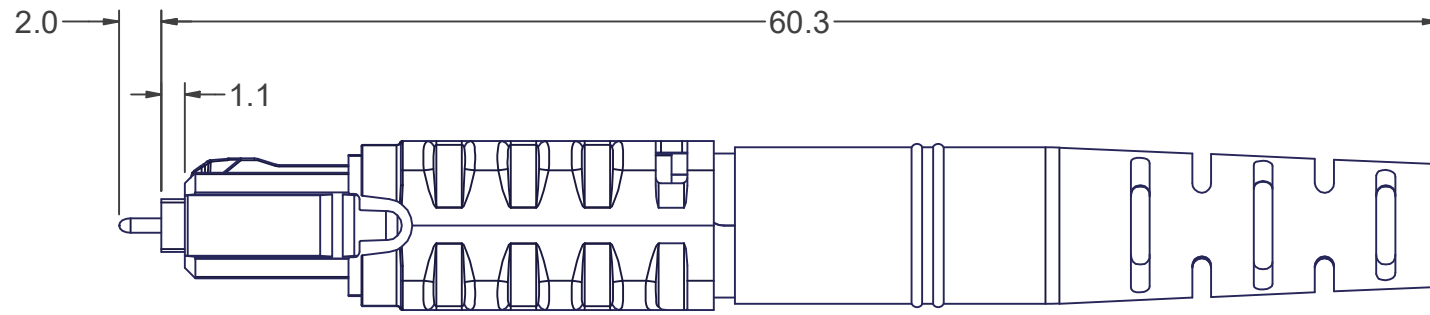
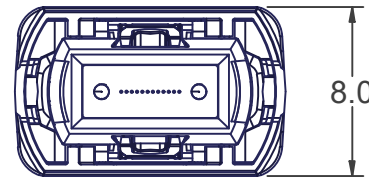

SECTION A-A

▲ DENOTES CRITICAL DIMENSION

USCONEC LTD. PROPRIETARY
 THIS DOCUMENT AND THE ASSOCIATED DATA CONTAIN RESTRICTED INFORMATION THAT IS USCONEC LTD. PROPERTY. DISCLOSE OR DUPLICATE FOR OTHERS ONLY AS AUTHORIZED BY USCONEC LTD.

Material:

REV.	DATE	DESCRIPTION	ECN

CUSTOMER DRAWING

DIMENSIONS FOR REFERENCE ONLY

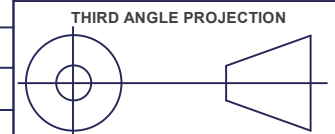

METRIC/mm



Hickory, NC
 800-769-0944
 www.usconec.com

TITLE
 KIT, MTP® PRO CONN., 3.8 - 4.2 mm
 RND CBL, HIGH SPRING FORCE

SIZE A3	S&M Part No.: SEE TABLE	DWG NO. C18616	REV D
SCALE N.T.S.	Drafter M.McCROSKEY	Date: 5/9/2018	SHEET 2 OF 2