

| P/N | COLOR |
|-------|----------------|
| 17252 | BLUE |
| 17335 | GREEN |
| 17923 | AQUA |
| 17925 | HEATHER VIOLET |

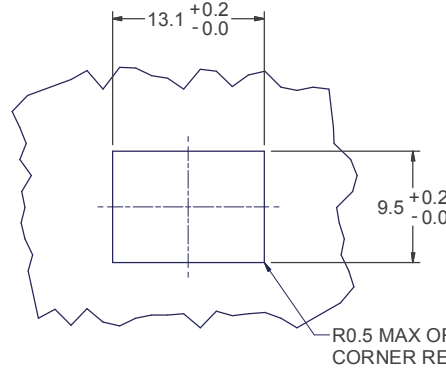

RECOMMENDED MOUNTING CUTOUT

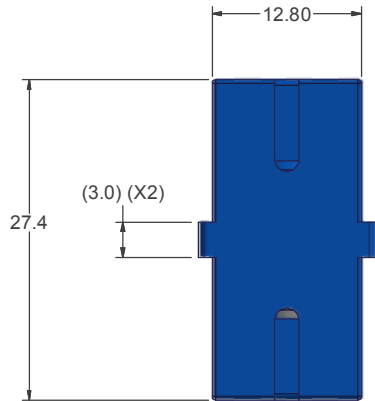
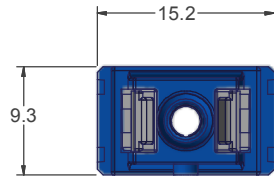
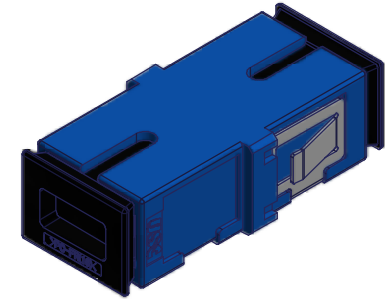

VIEW SHOWING CAPS & CLIP

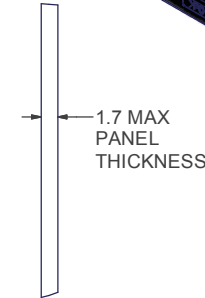

1.7 MAX
PANEL
THICKNESS

CAPS & CLIP NOT SHOWN ABOVE

NOTES:

- 1. UL94 V-0 Flammability

| PART | MATERIAL |
|---------------|----------------------------|
| SPLIT SLEEVE | ZIRCONIA |
| SLEEVE HOLDER | POLYETHERIMIDE, BLACK |
| HOUSING | POLYBUTYLENE TEREPHTHALATE |
| PIN | STAINLESS STEEL |
| PLATE | STAINLESS STEEL |
| CAP | POLYCARBONATE, BLACK |

USCONEC LTD. PROPRIETARY
THIS DOCUMENT AND THE ASSOCIATED DATA CONTAIN RESTRICTED INFORMATION THAT IS USCONEC LTD. PROPERTY. DISCLOSE OR DUPLICATE FOR OTHERS ONLY AS AUTHORIZED BY USCONEC LTD.

Material:

| REV | DATE | DESCRIPTION | ECN |
|-----|---------|-----------------|---------|
| X1 | 10/3/16 | - | mm |
| A | 2/3/17 | INITIAL RELEASE | 2001-mm |

CUSTOMER DRAWING

DIMENSIONS FOR REFERENCE ONLY

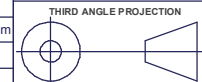

METRIC/mm

▲ DENOTES CRITICAL DIMENSION

USCONEC Hickory, NC
800-769-0944
www.usconec.com

TITLE
ADAPTER, SF, SC SIMPLEX,
REDUCED FLANGE

| | | | |
|--------|---------------|---------------|--------|
| SIZE | S&M Part No.: | DWG NO. | REV |
| B | SEE TABLE | C17252 | A |
| SCALE | Drafter | Date: | SHEET |
| N.T.S. | MMcCROSKEY | 10/3/2016 | 1 OF 1 |