

8 7 6 5 4 3 2 1

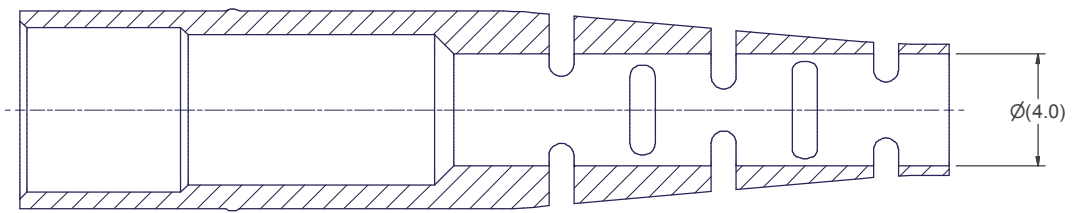

SECTION A-A

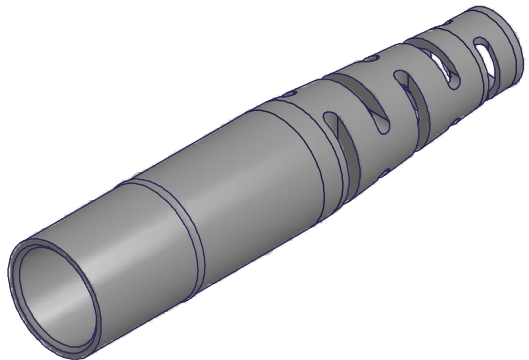
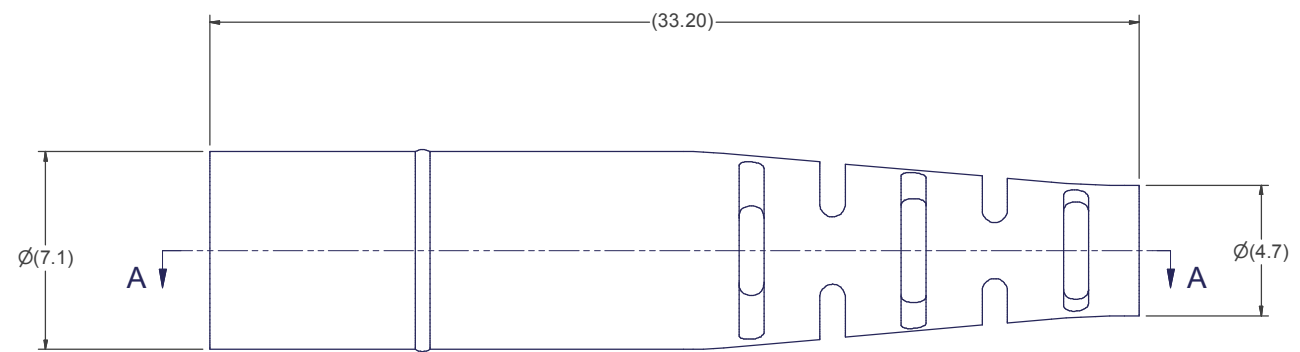
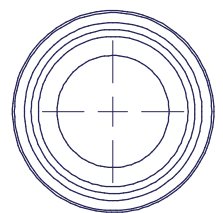

P/N	DESCRIPTION
12957	BLACK-ANTIMICROBIAL

**USCONEC LTD. PROPRIETARY**  
THIS DOCUMENT AND THE ASSOCIATED DATA CONTAIN RESTRICTED INFORMATION THAT IS USCONEC LTD. PROPERTY. DISCLOSE OR DUPLICATE FOR OTHERS ONLY AS AUTHORIZED BY USCONEC LTD.

**Material:** TPE - MAT'L SPEC #C13710

REV	DATE	DESCRIPTION	ECN
A	4/6/11	INITIAL RELEASE	01236

**CUSTOMER DRAWING**

DIMENSIONS FOR REFERENCE ONLY

THIRD ANGLE PROJECTION

**METRIC/mm**

▲ DENOTES CRITICAL DIMENSION

Hickory, NC  
800-769-0944  
[www.usconec.com](http://www.usconec.com)

**USCONEC**

**TITLE**  
BOOT, ROUND, MTP®, 3.4 - 3.8 mm CABLES

SIZE	S&M Part No.:	DWG NO.	REV
B	SEE CHART	<b>C12957</b>	A
SCALE	Drafter	Date:	SHEET
N.T.S.	H. NGUYEN	2/4/2010	1 OF 1

8 7 6 5 4 3 2 1