

8 | 7 | 6 | 5 | 4 | 3 | 2 | 1

D

C

B

A

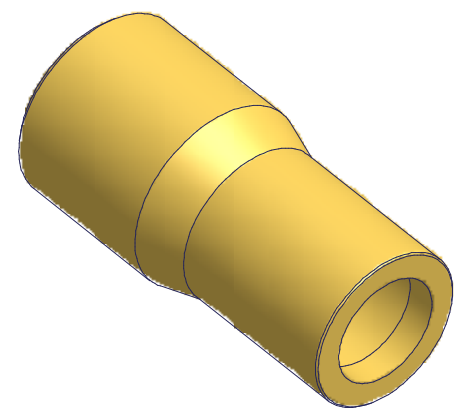
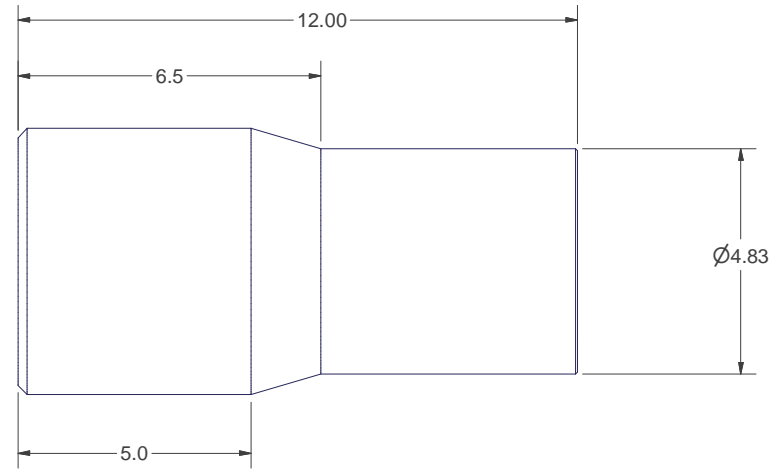
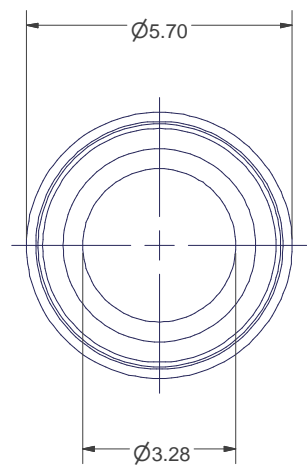

D

C

B

A

NOTES:

1. MATERIAL TO HAVE BRIGHT BRASS FINISH ONLY, NO TARNISH OR CORROSION ALLOWED.

Material:		BRASS - SEE NOTE 1	
REV.	DATE	DESCRIPTION	ECN
A	6/11/01	RELEASE TO SALES	00104
B	2/16/05	ADD NOTE ABOUT BRIGHT BRASS	00636

CUSTOMER DRAWING

US CONE C

▲ DENOTES CRITICAL DIMENSION.

Hickory, NC
800-769-0944
www.usconec.com

TITLE
CRIMP BAND, MTRJ

THIRD ANGLE PROJECTION

METRIC/mm

SIZE	S&M Part No.:	DWG NO.	REV
B	6993	C10583	B
SCALE	Drafter	Date:	SHEET
N.T.S.	F. COPE	6/11/2001	1 OF 1

8 | 7 | 6 | 5 | 4 | 3 | 2 | 1