

PRODUCT DESCRIPTION	
PRODUCT NAME	OPTIPOP P250
MAIN UNIT WEIGHT	0.2 GRAM
PACKAGING	5 Pieces/pack X 40 packs/box (= 200 sticks/box)
BAG DIMENSIONS	25mm X 100mm
WEIGHT	34 GRAMS / BAG

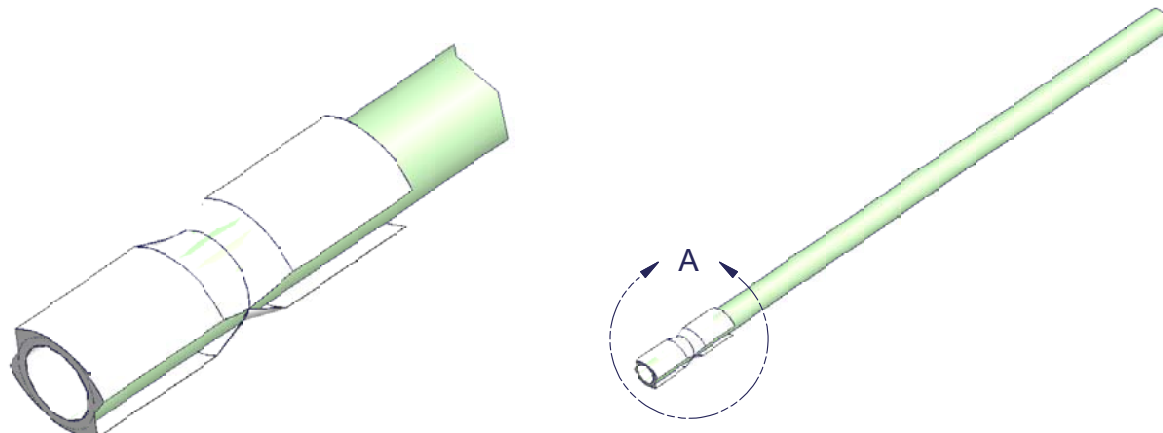

DETAIL A
SCALE 6 : 1

2.5mm I.D. CLEANS 2.5mm FERRULES
AND INNER CONNECTOR HOUSING

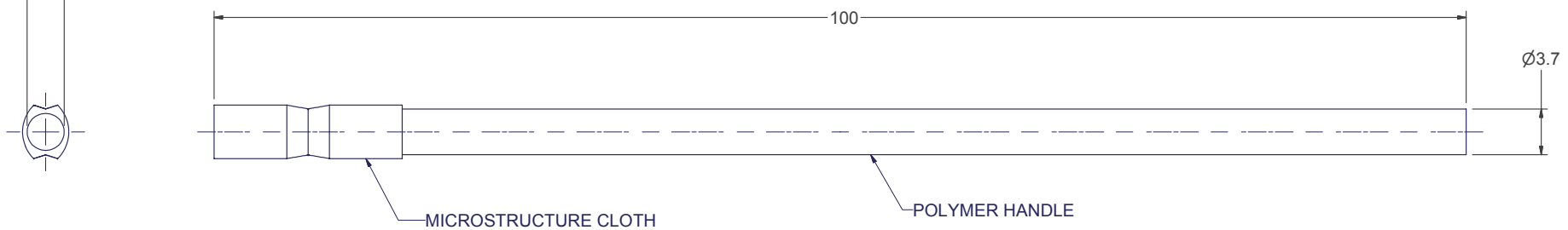

Material:		N/A	
REV.	DATE	DESCRIPTION	ECN
A	2/10/03	RELEASE TO SALES	00394

CUSTOMER DRAWING

DIMENSIONS FOR REFERENCE ONLY

THIRD ANGLE PROJECTION

METRIC/mm

▲ DENOTES CRITICAL DIMENSION.

USCONEC Hickory, NC
800-769-0944
www.usconec.com

TITLE **CLEANER, PIPE, 2.50mm DIA**

SIZE	S&M Part No.: 6364	DWG NO.	REV
B	Drafter F. COPE	C10956	A
SCALE	Date: 2/11/2003	SHEET 1	OF 1
N.T.S.			