

8 | 7 | 6 | 5 | 4 | 3 | 2 | 1

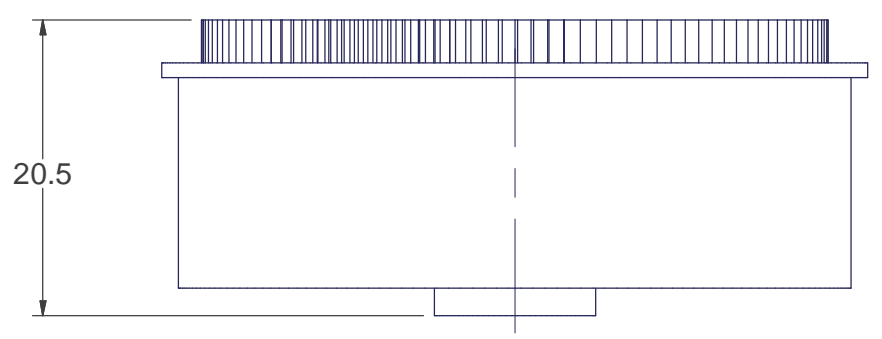

PRODUCT DESCRIPTION	
CONSTRUCTION	CLOTH ON A REEL
MAIN UNIT DIMENSIONS	49 DIA X 19.2 (SINGLE REEL)
CLOTH DIMENSIONS	(L)13m X (W)16mm
PACKAGING DIMENSIONS	6 REELS/BOX (With installation instructions)
WEIGHT	140 GRAMS

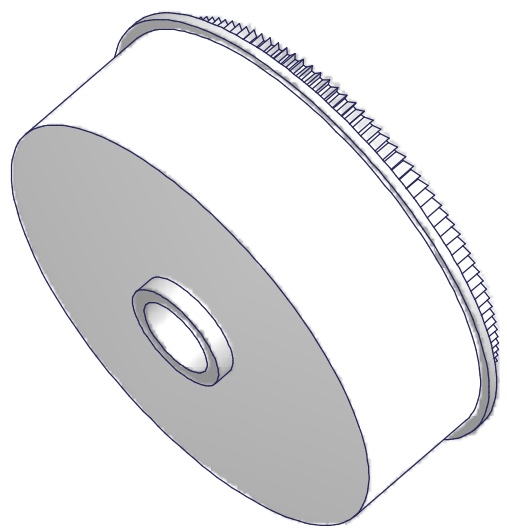
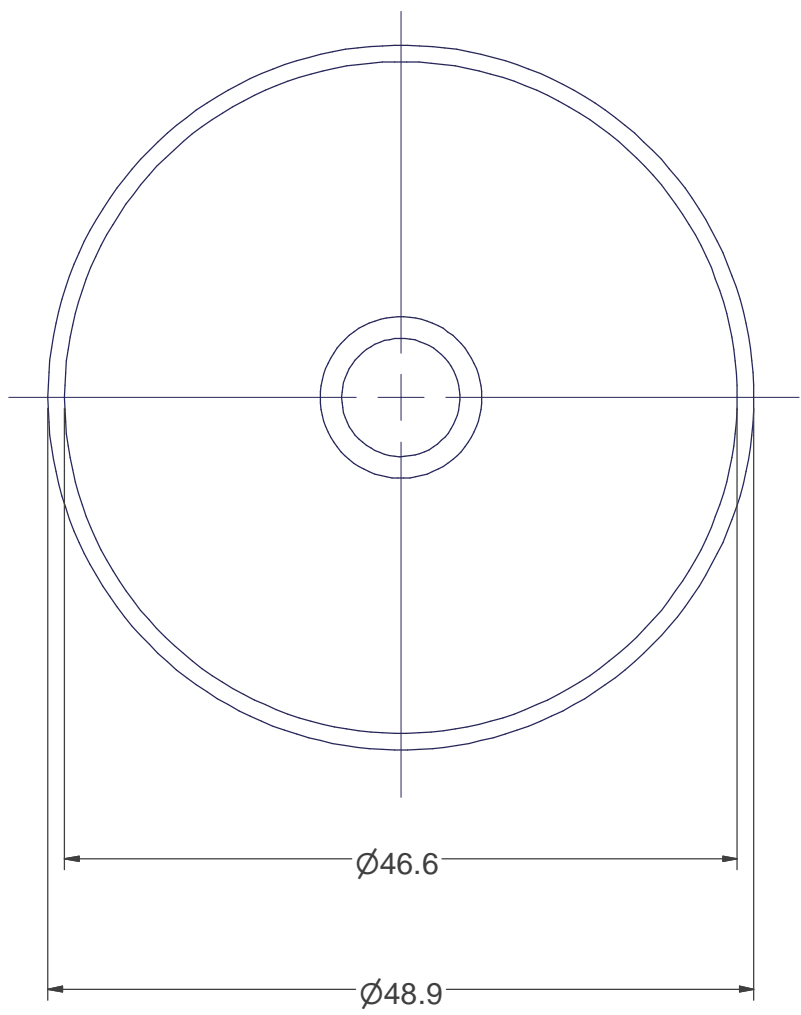

Material:

REV.	DATE	DESCRIPTION	ECN
A	11/27/02	RELEASE TO SALES	00370
B	2/7/03	CHART TEXT "DESCRIPTION" WAS "DISCRIPTION"	00393
C	3/7/08	ADDED CLOTH DIMENSIONS TO TABLE	01004

▲ DENOTES CRITICAL DIMENSION.

CUSTOMER DRAWING

USCONEC Hickory, NC
800-769-0944
www.usconec.com

TITLE
CLEANER, REEL
REPLACEMENTS, 6-PACK

SIZE **B** S&M Part No.: 6232 DWG NO. **C10904** REV **C**

SCALE N.T.S. Drafter J. Howard Date: 11/8/2002 SHEET 1 OF 1

8 | 7 | 6 | 5 | 4 | 3 | 2 | 1